

Standard Equipment/Optional Equipment

Standard Equipment

Fully suspended operator compartment (2t & 2.5t)	Automatic speed reduction when cornering
Suspended floor (T14 S)	Electromagnetic emergency brake acting proportionally to the load weight
Narrow chassis width	CAN bus technology
Key switch or PIN Code access	Drive wheel Polyurethane
Multifunction coloured display as well as hourmeter, maintenance indication, battery discharge indicator and internal fault code indication	Single load wheels Polyurethane
Power assisted steering	Battery compartment for 3PzS and 4PzS
Automatic speed reduction when cornering	Width over fork carriage: 520mm, 540mm, 560mm & 680mm
ECO-Mode with up to 12% energy savings	Fork carriage length: 1000mm, 1150mm, 1160mm, 2400mm (overhang 188mm) and 2400mm (overhang 563mm)
Drive wheel position mentioned in display (S)	Protection -10°C
Steering wheel left or right side (S)	

Optional Equipment

Drive wheels: cushion rubber, synthetic cushion rubber non marking, wet grip	Pole on left side for additional support
Load wheels: tandem polyurethane, single polyurethane greasable, tandem polyurethane greasable	Pole on right side for flashing beacon
Lateral battery change 3PzS and 4PzS with ergonomic battery un/locking with lever	Support Clipboard DIN A4
Load backrests with h=1115mm and h=1875mm	Support data terminal incl. power supply cable 24V
Floor compensator	Mobile or Fixed battery stand
Speed reduction if forks lowered	Automatic battery watering system
Linde Connected Solutions: ac:access control (PIN or RFID Dual), an:usage analysis and dt:crash detection	Cold store protection -35°C
	Other options available on request



Stand-on Pallet Truck
Capacity 1400, 2000 & 2500 kg
T14 S, T20 S/SF, T25 S/SF Series 1154

Safety

High performance combined with safety. The operator's body remains safely within the chassis contours at all time. A deadman foot switch ensures instant braking response when necessary. The truck comes rapidly to a smooth stop thanks to an electromagnetic brake which acts proportionally to the load on the forks. Due to its compact chassis, the fork tips are easily visible ensuring safe load handling.

Performance

One of the truck's great strengths is its productivity. The compact drive unit permits precise manoeuvring for reaching the utmost performance. With capacity from 1,400 kg up to 2,500 kg, and a powerful maintenance-free 3 kW drive motor providing a maximum speed of 12 km/h, the Stand-on Pallet Truck is ideally suited to intensive lorry loading and unloading and rapid pallet transfer applications.

Comfort

The fully suspended operator compartment, completely decoupled from the chassis keeps the driver concentrated and maintains high efficiency levels throughout the shift. Allied with a padded backrest, the operator's stability is assured.

Reliability

Rugged construction and the use of tried and tested components make this a truck that can be relied on. Smooth fork entry into close pallets is assured by the profiled shape of the fork tips and the entry skid. These features guarantee a longer operating life combined with fast, safe and easy load handling.

Service

Efficiency at work and efficiency in servicing with cost effective maintenance routine. Easy access to all components and maintenance-free technology also play their part in increasing truck uptime and availability. CAN bus connectivity provides a computerised diagnostic system for rapid analysis to ensure maintenance intervals are also minimised.

Features

Fully suspended operator compartment

- Standard on 2t & 2.5t versions
- Suspended floor on T14 S
- Decoupled stand-on platform and drive unit from the chassis (S and SF)
- Comfortable and curved padded backrest (S)
- Significant reduction of vibrations transmitted to the body
- Ergonomic 90° driving position (S)

Narrow chassis

- Chassis width = 770mm
- Small I2 dimension = 800mm
- High maneuverability when operating in lorries or confined spaces
- High stand-on position for good visibility
- Stable 4 point configuration



Workstation

- Multifunctional coloured display with easy & ergonomic menu structure
- Truck access control by PIN code or ignition key
- Wide and deep storage compartment for work gloves, writing utensils etc
- Support clipboard DIN A4, flashing beacon available as option



Tip Control

- Traction, lift controls and horn grouped in one single ergonomic unit
- Enables one-handed operations
- High modularity : either left or right side
- Height adjustable hand platform
- Available on Side (S) version



Battery & chargers

- Battery tray for DIN batteries
- 24V batteries : capacities from 345 Ah (3PzS) to 500 Ah (4PzS)
- Lateral battery change with ergonomic battery lever & spring (option)

Multiple driving positions

- Side (S) version: vertical to forks direction
- Tip Control, an innovative drive and lift control unit
- Steering wheel on right or left side
- Ergonomic driving position with comfortable backrest
- Stand Front (SF) version: in forks direction
- Twin grip handle bar

Drive control and settings

- Steering effort adjusts automatically to speed and turning radius
- Speed is automatically reduced in relation to the steering angle
- Power settings available
- ECO-Mode up to 12% energy savings to finish shift with low battery status



AC motor

- Powerful, 3 kW drive motor
- Maintenance-free, moisture and dust proof AC motor
- Three power settings
- Gradient performance of max. 15% (laden)
- No roll back on gradient starts
- High torque motor negotiates loading docks with ease

Technical Data according to VDI 2198

		LINDE						
		T145	T205	T255	T205F	T255F		
Characteristics	1.1	Manufacturer	LINDE	LINDE	LINDE	LINDE	LINDE	
	1.2	Manufacturer's type designation	T145	T205	T255	T205F	T255F	
	1.2a	Series	1154-00	1154-00	1154-00	1154-00	1154-00	
	1.3	Power unit	Battery	Battery	Battery	Battery	Battery	
	1.4	Operation	Stand on	Stand on	Stand on	Stand on	Stand on	
	1.5	Load capacity/Load	Q (t)	1.4	2.0	2.5	2.5	
	1.6	Load centre distance	c (mm)	600	600	800	600	800
	1.8	Axle centre to fork face	x (mm)	895 / 965 ¹⁾²⁾	895 / 965 ¹⁾²⁾	1345 / 1415 ¹⁾²⁾	895 / 965 ¹⁾²⁾	1345 / 1415 ¹⁾²⁾
	1.9	Wheelbase	y (mm)	1533 / 1603 ¹⁾²⁾	1533 / 1603 ¹⁾²⁾	1983 / 2053 ¹⁾²⁾	1533 / 1603 ¹⁾²⁾	1983 / 2053 ¹⁾²⁾
Weights	2.1	Service weight	(kg)	800 ³⁾⁴⁾	848 ³⁾⁴⁾	944 ³⁾⁴⁾	848 ³⁾⁴⁾	944 ³⁾⁴⁾
	2.2	Axle load with load, front/rear	(kg)	881 / 1319 ³⁾⁴⁾	1057 / 1791 ³⁾⁴⁾	1426 / 2018 ³⁾⁴⁾	1057 / 1791 ³⁾⁴⁾	1426 / 2018 ³⁾⁴⁾
	2.3	Axle load without load, front/rear	(kg)	612 / 188 ³⁾⁴⁾	672 / 176 ³⁾⁴⁾	739 / 205 ³⁾⁴⁾	672 / 176 ³⁾⁴⁾	739 / 205 ³⁾⁴⁾
Wheels/Tyres	3.1	Tyres rubber, SE, pneumatic, polyurethane	V+P/P ⁵⁾	V+P/P ⁵⁾	V+P/P ⁵⁾	V+P/P ⁵⁾	V+P/P ⁵⁾	
	3.2	Tyre size, front	Ø 230 x 90	Ø 254 x 102	Ø 254 x 102	Ø 254 x 102	Ø 254 x 102	
	3.3	Tyre size, rear	Ø 85 x 105 (2x Ø 85 x 80) ⁶⁾	Ø 85 x 105 (2x Ø 85 x 80) ⁶⁾	Ø 85 x 105 (2x Ø 85 x 80) ⁶⁾	Ø 85 x 105 (2x Ø 85 x 80) ⁶⁾	Ø 85 x 105 (2x Ø 85 x 80) ⁶⁾	
	3.5	Wheels, number front/rear (x = driven)	1x + 2 / 2 (1x + 2 / 4) ¹⁾	1x + 2 / 2 (1x + 2 / 4) ¹⁾	1x + 2 / 2 (1x + 2 / 4) ¹⁾	1x + 2 / 2 (1x + 2 / 4) ¹⁾	1x + 2 / 2 (1x + 2 / 4) ¹⁾	
	3.6	Track width, front	b10 (mm)	484 ²⁾	484 ²⁾	484 ²⁾	484 ²⁾	484 ²⁾
Dimensions	3.7	Track width, rear	b11 (mm)	395 ²⁾	395 ²⁾	395 ²⁾	395 ²⁾	395 ²⁾
	4.4	Lift	h3 (mm)	125 ²⁾	125 ²⁾	125 ²⁾	125 ²⁾	125 ²⁾
	4.15	Height, lowered	h13 (mm)	88	88	88	88	88
	4.19	Overall length	l1 (mm)	1950 ²⁾	1950 ²⁾	2400 ²⁾	1950 ²⁾	2400 ²⁾
	4.20	Length to fork face	l2 (mm)	800 ²⁾	800 ²⁾	800 ²⁾	800 ²⁾	800 ²⁾
	4.21	Overall width	b1/b2 (mm)	770 ²⁾	770 ²⁾	770 ²⁾	770 ²⁾	770 ²⁾
	4.22	Fork dimensions DIN ISO 2331	s/e/l (mm)	55 x 165 x 1150	55 x 165 x 1150	55 x 165 x 1600	55 x 165 x 1150	55 x 165 x 1600
	4.25	Fork spread	b5 (mm)	520/540/560/680 ²⁾	520/540/560/680 ²⁾	520/540/560/680 ²⁾	520/540/560/680 ²⁾	520/540/560/680 ²⁾
	4.32	Ground clearance, centre of wheelbase	m2 (mm)	30 ⁷⁾	30 ⁷⁾	30 ⁷⁾	30 ⁷⁾	30 ⁷⁾
	4.34.1	Aisle width for pallets 1000 x 1200 crossways	Ast (mm)	2015 ⁸⁾	2015 ⁸⁾	3226 ⁸⁾⁹⁾	2015 ⁸⁾	3226 ⁸⁾⁹⁾
4.34.2	Aisle width with pallet 800 x 1200 along forks	Ast (mm)	2215 ⁸⁾	2215 ⁸⁾	3826 ⁸⁾⁹⁾	2215 ⁸⁾	3826 ⁸⁾⁹⁾	
4.35	Turning radius	Wa (mm)	1710 / 1780 ¹⁾	1710 / 1780 ¹⁾	2160 / 2230 ¹⁾	1710 / 1780 ¹⁾	2160 / 2230 ¹⁾	
Performance	5.1	Travel speed, with/without load	(km/h)	8 / 10 ¹⁰⁾	10 / 12 ¹⁰⁾	10 / 12 ¹⁰⁾	10 / 12 ¹⁰⁾	10 / 12 ¹⁰⁾
	5.2	Lifting speed, with/without load	(m/s)	0.04 / 0.047 ⁴⁾	0.036 / 0.043 ⁴⁾	0.027 / 0.034 ⁴⁾	0.036 / 0.043 ⁴⁾	0.027 / 0.034 ⁴⁾
	5.3	Lowering speed, with/without load	(m/s)	0.074 / 0.07 ⁴⁾	0.064 / 0.059 ⁴⁾	0.067 / 0.059 ⁴⁾	0.064 / 0.059 ⁴⁾	0.067 / 0.059 ⁴⁾
	5.8	Maximum climbing ability, with/without load	(%)	16.0 / 20.0	15.0 / 20.0	9.0 / 20.0	15.0 / 20.0	9.0 / 20.0
Drive	5.10	Service brake		Electro-magnetic	Electro-magnetic	Electro-magnetic	Electro-magnetic	Electro-magnetic
	6.1	Drive motor rating S2 60 min	(kW)	2.3	3	3	3	3
	6.2	Lift motor rating at S3 15%	(kW)	1.2	1.2	1.2	1.2	1.2
	6.3	Battery according to DIN 43531/35/36 A,B,C,no		43 535 / B	43 535 / B	43 535 / B	43 535 / B	43 535 / B
	6.4	Battery voltage/rated capacity (5h)	(V)/(Ah)	24 / 345/375	24 / 345/375	24 / 345/375	24 / 345/375	24 / 345/375
	6.5	Battery weight (± 5%)	(kg)	287	287	287	287	287
	6.6	Power consumption according to VDI cycle	(kWh/h)	0.33	0.4	0.53	0.4	0.53
8.1	Type of drive unit		LAC	LAC	LAC	LAC	LAC	
10.7	Sound pressure level LpAZ (at the driver's seat)	(dB(A))	62 ¹¹⁾	65 ¹¹⁾	-	65 ¹¹⁾	-	

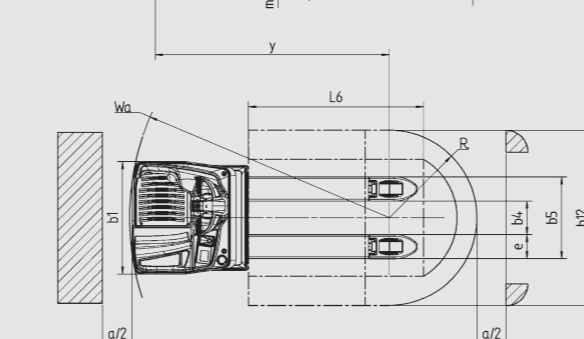
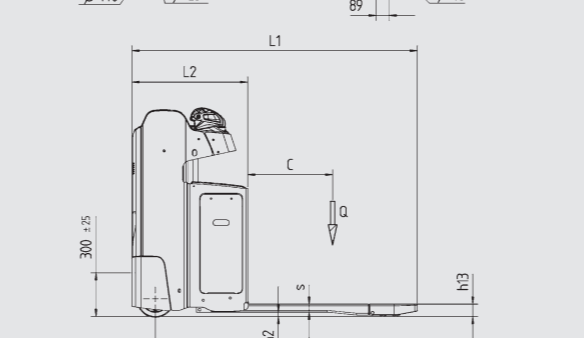
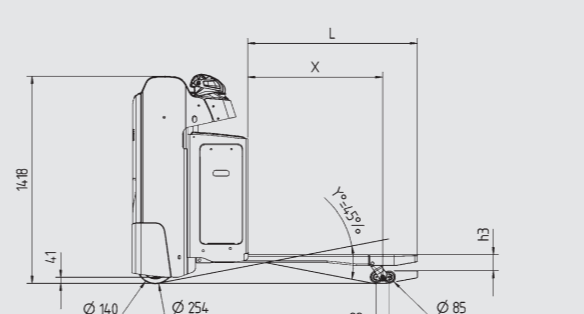
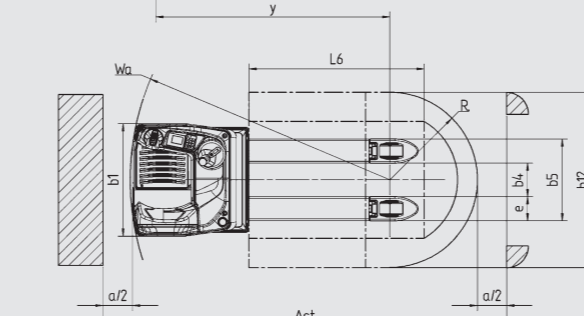
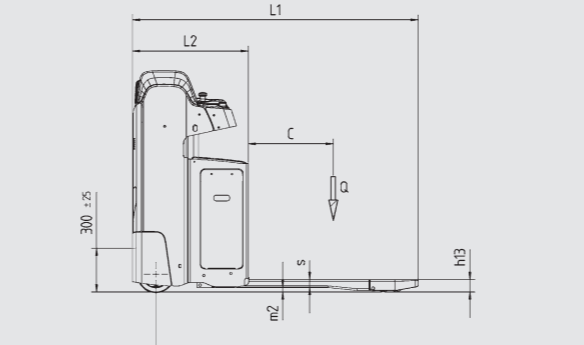
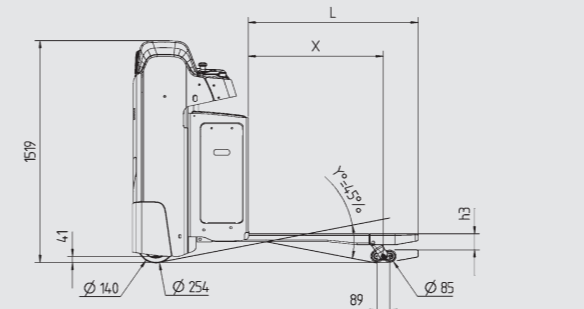

1) Forks upraised / lowered
 2) (± 5 mm)
 3) Figures with battery, see line 6.4/6.5.
 4) (± 10%)
 5) Solid rubber + polyurethane / polyurethane
 6) Figures in parenthesis with tandem load wheels.
 7) (± 2 mm)
 8) Including a 200 mm (min.) operating aisle clearance.
 9) With load: pallet 2x 800x1200 mm crosswise
 10) (± 5%)
 11) (± 2,5)