

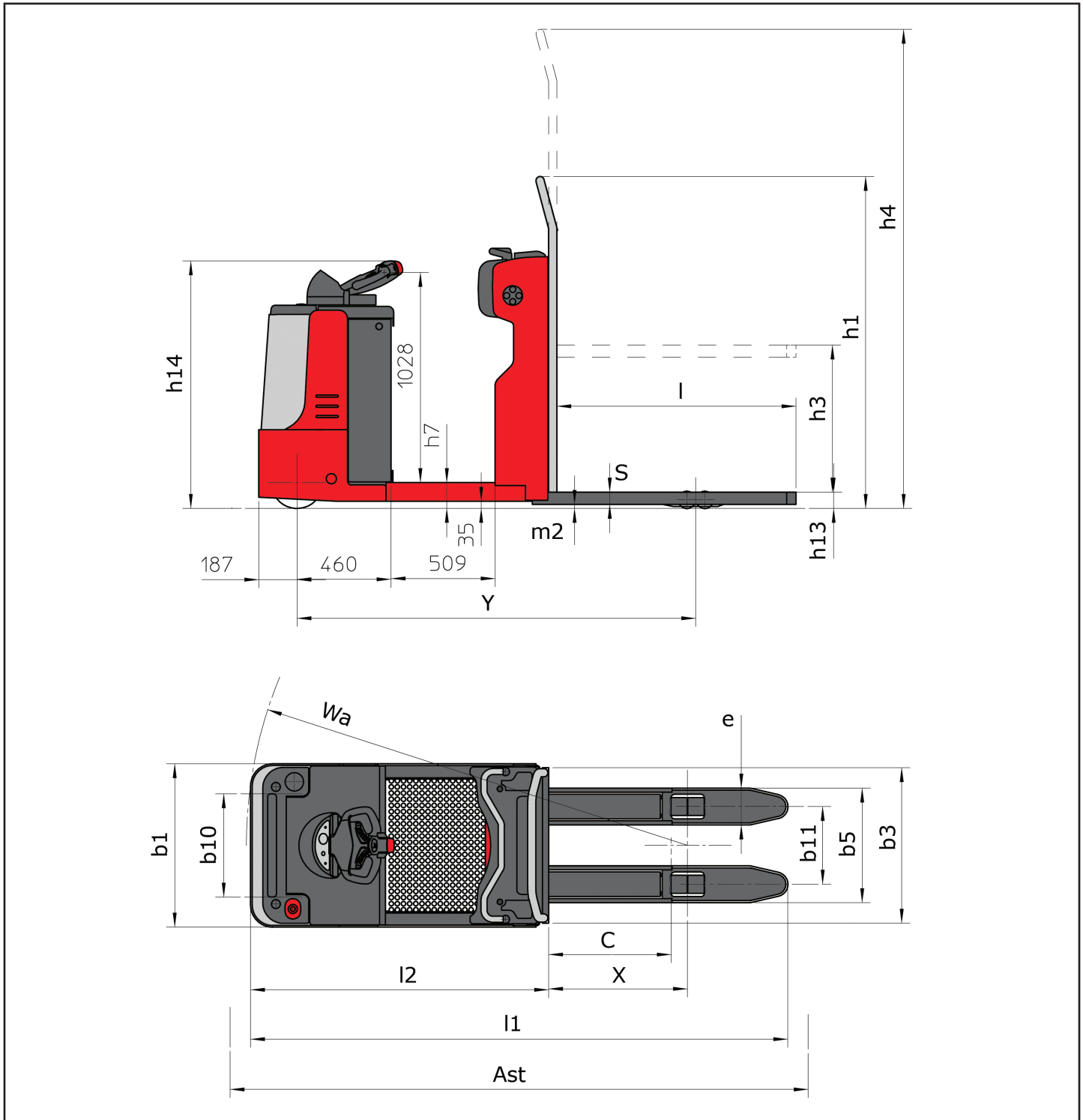

				MANITOU	MANITOU	MANITOU
				CI 20	CI 10 LC	CI 12 PF
		Q	kg	2000	1000	1200
		c	mm	600	600	600
		x	mm	949	680	240
		y	mm	2194	1950	1530
			kg	1450	1400	1780
			kg	1298/2152	946/1454	472/2508
			kg	928/522	896/504	650/1130
			mm	254 x 100	254 x 100	2 x 200 x 75
			mm	4 x 85 x 90	4 x 85 x 90	1 x 250 x 100
			mm	2 x 140 x 50	2 x 140 x 50	NA
				1 x 1/4	1 x 1/4	2/1
		b10	mm	505	505	NA
		b11	mm	370	380	665
		h1	mm	-	1625	
		h2		125	720	
		h3		-	2345	
		h4		130	130	
		h14	mm	1212	1212	1212
		h13	mm	85 ^{+5 -0}	80 ^{+5 -0}	50 ^{+5 -0}
		l1	mm	2602	2628	3108
		l2	mm	1432	1458	1958
		b1	mm	800	800	800
		s / e / l	mm	45 x 170 x 1150	60 x 180 x 1150	45 x 100 x 1150
		b3		760	760	790
		b5	mm	540	560	214 - 730
		m2	mm	40	20	50
		Ast	mm	2851	2878	3437
		Wa	mm	2400	2158	1742
			km/h	9 / 12	10 / 12	9 / 11
			m/s	0,10 / 0,15	0,08 / 0,12	0,08 / 0,18
			m/s	0,13 / 0,10	0,14 / 0,11	0,12 / 0,11
			%	6 / 10	6 / 10	6 / 10
			kW	2	2	2
			kW	2	2	2
				35B	35B	35B
			V/Ah	24 / 375	24 / 375	24 / 620
			kg	350	350	490
			db (A)	66	66	66



CI 12 PF		S 900	S 1450
		h3	mm
h1	mm	1440	1980
h2	mm	-	-
h4	mm	1440	1980

